

Installation, Maintenance and User Instructions

# Zip InLine

Electronically Controlled Instantaneous  
Water Heaters  
Models: DEX & DBX

Issued August 2014



The terms 'Zip' and 'InLine' are registered trademarks

Zip Heaters (UK) Ltd  
14 Bertie Ward Way  
Dereham  
Norfolk  
NR19 1TE

Telephone: 0845 6 005 005  
Mobile: 0345 6 005 005  
Fax: 01362 692448  
Web: [www.zipheaters.co.uk](http://www.zipheaters.co.uk)





9120-34136 August 2014 V1.05



Please read these instructions carefully **before** commencing installation of the InLine water heater.  
Please leave these instructions with the end user after installation.

## Contents

<b>Description</b>	1
<b>Approvals</b>	1
<b>Safety information</b>	2
<b>WARNING</b> 	2
<b>CAUTION</b> 	3
<b>Dimensions</b>	3
<b>Technical Data</b>	4
<b>Spare parts</b>	5
<b>Installation</b>	
Requirements	6
Installation site	6
Installing the wall bracket	7
Installing the connection pieces	7
Installing the appliance	8
Surface mounted installation	9
Electrical connection	9
Load shedding relay (DEX)	10
Electrical connection from below	10
Electrical connection from above	11
<b>Commissioning</b>	11
<b>Maintenance and cleaning</b>	13
<b>Operation (Model DEX only)</b>	14
<b>Fault finding</b>	16
<b>Warranty</b>	17

Please read these instructions carefully before commencing installation of the DEX - DBX Electronically controlled Instantaneous Water Heaters.

Please leave these instructions with the end user after installation.

To ensure you have the latest revision of this instruction manual, please visit [www.zipheaters.co.uk](http://www.zipheaters.co.uk) to download the latest copy.

In order to preserve our environment we ask that you dispose of this product correctly. Please contact Zip Customer Service for advice on 0845 6 005 005 or 0345 6 005 005.

## Description

Zip InLine DEX and DBX instantaneous water heaters are micro-processor controlled, pressure resistant water heaters suitable for supplying hot water to one or more outlets.

The heating element switches on automatically when the hot water tap is opened and switches off automatically when the hot water tap is closed.

The electronic control system automatically regulates the power consumption depending on the supply water temperature and flow rate to achieve the required outlet temperature within the power limit of the appliance.

Power consumption is also regulated based on outlet temperature to ensure the required temperature is achieved exactly to the degree and irrespective of fluctuations in voltage and water pressure.

For DEX the required outlet temperature can be entered on a keypad within the range 20°C to 60°C (DEX12 range is 20°C to 55°C) and can be read off the digital display.

For type DBX the factory set outlet temperature is 50°C and can be adjusted inside the appliance within the range 30°C to 60°C.

For DEX (\*excluding DEX12) a maximum inlet temperature of 70°C is suitable for use with preheated water from solar heating systems.

\*For DEX12 the maximum inlet temperature is 25°C.

## Approvals

Zip InLine DEX and DBX are VDE approved to the LVD and EMC directives and are CE endorsed.

Zip InLine DEX and DBX have been examined, tested and found when correctly fitted to comply with the requirements of the United Kingdom Water Regulations / Byelaws (Scotland).

The products are listed under the WRAS (Water Regulations Advisory Scheme) Water Fittings and Materials Directory.

### IMPORTANT:

**PLEASE READ THESE INSTRUCTIONS CAREFULLY.**

**NOTE THE SAFE OPERATIONAL REQUIREMENTS, WARNINGS AND CAUTIONS. USE THIS PRODUCT CORRECTLY AND WITH CARE FOR THE PURPOSE FOR WHICH IT IS INTENDED. FAILURE TO DO SO MAY CAUSE DAMAGE AND/OR PERSONAL INJURY, AND WILL INVALIDATE THE WARRANTY. RETAIN THESE INSTRUCTIONS FOR FUTURE USE.**

### WARNING:



Situations that could cause injury to yourself or others.

### CAUTION:



Situations that could cause damage to your appliance or other equipment.

### NOTE:

Notes, usage tips or additional information.

## Safety Information

### WARNING

- **Installation, commissioning and maintenance of this appliance must only be carried out by a competent installer who will then be responsible for adhering to all relevant standards and regulations.**
- **The front cover of the appliance must never be opened before disconnecting the appliance from the mains power supply.**
- To protect the appliance, a circuit breaker or fuse must be fitted with a rating suitable for the nominal current of the appliance.
- The appliance must be permanently connected to the supply through an isolating switch with a contact separation of at least 3mm in all poles and be protected by a suitably rated RCD.
- The cross sectional area of the connection cable must be appropriate for the power rating and location of the appliance. See Technical Data.
- The connecting cable must be adequately secured.
-  This appliance must be earthed at all times.
- Check that the power supply is switched off prior to electrical connection.
- The appliance, its wiring and piping must not be modified in any way.
- In case of malfunction isolate the power supply immediately. In case of leaks also isolate the water supply. Repairs must only be carried out by Zip Heaters (UK) Ltd or an authorised Zip service engineer.
- Temperatures in excess of approximately 43°C are perceived as hot, especially by children, and may cause a feeling of burning.
- This appliance can be used by children aged from 8 years and above and persons with reduced physical, sensory or mental capabilities or lack of experience and knowledge if they have been given supervision or instruction concerning the use of the appliance in a safe way and understand the hazards involved.  
Children shall not play with the appliance.  
Cleaning and user maintenance shall not be made by children without supervision.
- When the appliance has been in use for some time, the fittings may be very hot.
- If inlet temperature is up to 70°C (eg. fed from a solar supply) mixing with cold water will be required to ensure a safe temperature at the outlet.

## CAUTION

- Optimum operation is ensured at a water flow pressure of 0.2 to 0.4 MPa (2-4 bar). The appliance must not be subjected to pressure exceeding 1.0 MPa (10 bar).
- The appliance must only be used when correctly installed and in perfect working order.
- The appliance must be installed in a frost-free room and must never be exposed to frost.
- The DEX and DBX range is not intended for use with thermostatic mixing valves or taps.
- The appliance must be completely filled with water before being switched on.
- Before commissioning for the first time and each time the appliance is emptied (e.g. due to work on the plumbing system or maintenance), the appliance must be vented by opening and closing the hot water tap until all air has been eliminated from the water heater and no more air emerges before re-connecting to the electrical supply.
- The appliance must only be used for heating potable water. The specific water resistance must not fall below the required value indicated on the rating plate. The appliance must not be used for any other purpose.
- Incoming water temperature must not exceed that stated in Technical data.
- The Zip InLine is intended for connection to mains supply only. In any other case please contact Zip on 0845 6 005 005 or 0345 6 005 005 for advice.
- **Zip Heaters (UK) Ltd cannot be held liable for any damages caused by failure to observe these instructions.**

## Dimensions

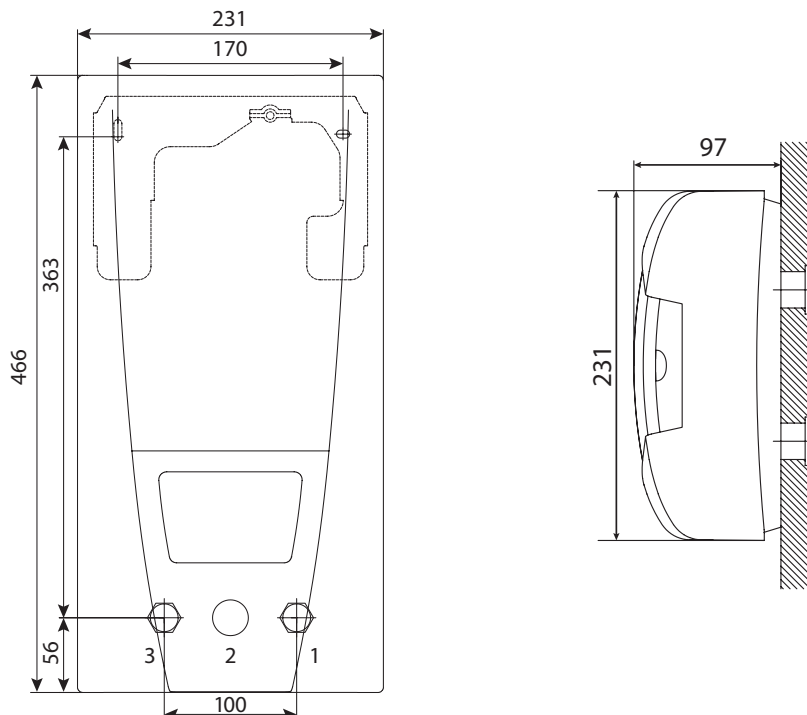

## Technical data

Model	DEX <sup>(1)</sup>				
	DEX12 <sup>(1)</sup>	DBX18	DBX21	DBX24	DBX27
Nominal supply voltage	1/N/PE 230V~	3/PE 380-400V~			3/PE 400V~
Power Rating (kW)	8.8 / 11.0 <sup>(1)</sup>	18.0	21.0	24.0	27.0
Rated Current (A)	38 (8.8kW) 48 (11.0kW)	26	30	35	39
Element type	Bare wire				
Rated pressure	1 MPa (10 bar)				
Temperature adjustment range					
DEX	20°C - 55°C	20°C - 60°C			
DBX		30°C - 60°C			
Maximum inlet temperature					
DEX	25°C	70°C			
DBX		30°C			
Minimum flow rate (l/min)	2.5				
Maximum flow rate (l/min)					
DEX	5.0	8.0			
DBX		7.0	8.0	8.0	9.0
Flow rate @ 38°C (l/min) <sup>(2)</sup>	4.8 (8.8kW) 6.1 <sup>(3)</sup> (11.0kW)	9.8 <sup>(3)</sup>	11.4 <sup>(3)</sup>	13.0 <sup>(3)</sup>	14.8 <sup>(3)</sup>
Flow rate @ 50°C (l/min) <sup>(2)</sup>	3.3 (8.8kW) 4.1 (11.0kW)	6.8	7.9	9.0 <sup>(3)</sup>	10.2 <sup>(3)</sup>
Pressure loss @ 2.5 l/min					
@ 9.0 l/min					
0.2 bar					
1.3 bar <sup>(4)</sup>					
Required specific water resistance @ 15°C					
DEX	>1300 ohm.cm	>1100 ohm.cm			
DBX		>1300 ohm.cm			
Dimensions H x W x D (mm)	466 x 231 x 97				
Maximum weight (kg)	3.7				
Rated volume (litres)	0.4				
Water connections (BSP)	1/2"				
Protection class	IP25				

<sup>(1)</sup> Power rating selected at time of installation

<sup>(2)</sup> At 12°C incoming water temperature

<sup>(3)</sup> Mixed with cold water at the outlet

<sup>(4)</sup> Without flow regulator

All data quoted at nominal supply voltage. Standard European voltage tolerances of -6% to + 10% may be applied.

A minimum water pressure of 0.2 MPa (2 bar) is recommended for optimum performance.

The appliance must not be subject to more than 1 MPa (10 bar).

## Spare Parts

When ordering spare parts, please always specify the appliance model and serial number.

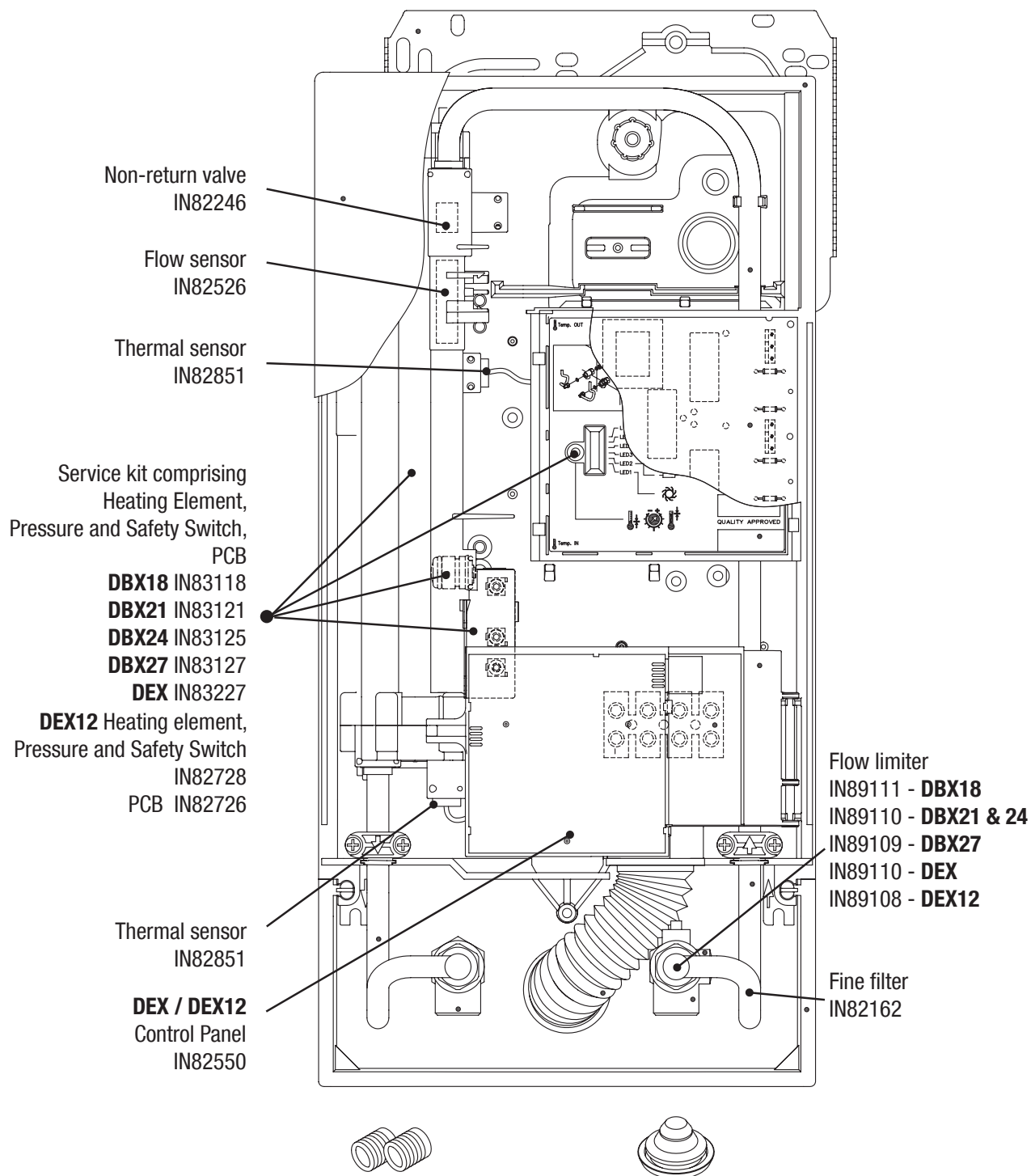

## **Installation Requirements**

- These instructions must be read and fully understood before commencing the installation. If in doubt, or in need of further guidance please ring Zip on 0845 6 005 005 or 0345 6 005 005.
- Zip InLine water heaters must be installed by a competent person familiar with electric instantaneous water heaters.
- Installations must comply fully with UK Water Regulations and any Local Authority requirements.
- The electrical installation including earthing and cross bonding should comply with current IEE regulations and any Local Authority requirements.
- Zip InLine water heaters must be installed according to the specification on the rating plate and the technical specifications.
- To protect the appliance, a circuit breaker or fuse must be fitted with a rating suitable for the nominal current of the appliance. (See Technical Data Section on page. 4).
- The appliance must be permanently connected to the supply through an isolating switch with a contact separation of at least 3mm in all poles and be protected by a suitably rated RCD.
- The cross sectional area of the connection cable must be in accordance with the power rating of the appliance and the specific requirements of the installation site up to a maximum cable size of 10mm<sup>2</sup>.
- Take care to protect the wiring from damage during installation and ensure that any uninsulated wiring is not directly accessible after installation.
- Check that the power supply is switched off prior to electrical connection.
- **Installation site**
- The installation site must be free from frost at all times.
- For maintenance work a shut off valve should be installed in the water supply line to the heater.
- The unit should be positioned as close as possible to the outlet to minimise heat loss. The recommended maximum distance is 2 meters.
- The appliance complies with protection type IP25 and may therefore be installed in protection zone 1.
- When considering the location of the heater, consideration should be given to the safe and visible disposal of any water resulting from leaks and seepage. This is particularly relevant when the heater is located in a cupboard or any concealed location. For guidance please call Zip Heaters (UK) Ltd on 0845 6 005 005 or 0345 6 005 005.
- Hot and cold water connecting pipes should be WRAS approved and of copper or steel construction. Plastic pipes may only be used if conforming to DIN 16893 Series 2. The hot water pipes must be thermally insulated.



- The specific resistance of the supply water must be at least 1100Ωcm at 15°C. for type DEX, and at least 1,300 ohm.cm 15°C for type DBX and DEX12. The specific resistance can be checked with the local water supply company.

### Installing the wall bracket

1. Thoroughly flush the water supply pipes before installation to remove any water borne debris.
2. Using a 12mm hexagon key, screw the screw in nipples into the wall connections. After tightening the double nipples must protrude by 12mm.
3. Hold the mounting template on the wall and align it so that the holes in the template fit over the connections. Use the template to locate the drilling positions and drill them with a 6mm bit, ensuring that there are no hidden cables or pipe-work. Attach the wall bracket using the fixings and screws supplied.
4. Offset tiling or uneven surfaces can be compensated for by up to 30mm with the aid of the spacers supplied. The spacers are fitted between the wall and the wall bracket.

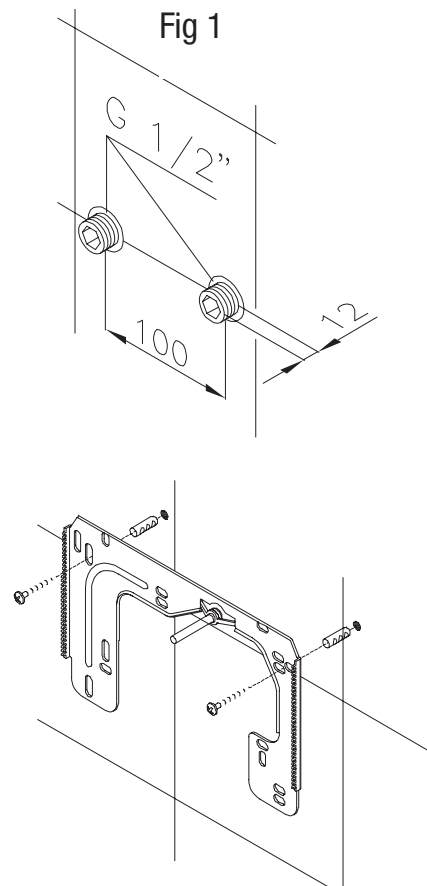

### Installing the connection pieces

1. Screw the cold water connection piece (A) with the union nut and the 1/2" seal onto the cold water connection.
2. Screw the hot water connection piece (B) with the union nut and the 1/2" seal onto the hot water connection.

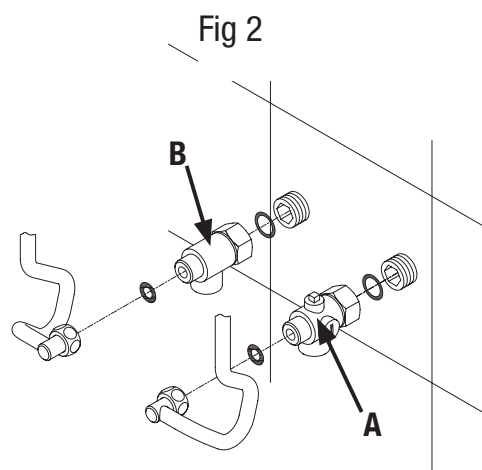

## Installing the appliance

1. Remove the appliance cover by first removing the fascia panel then unscrewing the fixing screw.
2. If the power supply cable is to be connected in the upper part of the appliance follow instructions 1 to 3 for “Electrical Connection From Above” on page 11. This is not applicable to model DEX12.
3. Place the appliance on the wall bracket with the threaded stud through the fixing hole in the back plate.  
If necessary the threaded stud can be carefully bent through a maximum of approximately 30° to allow it to align with the fixing hole (see Fig 4). However, it must be ensured that the water connection pipes can be connected to the appliance without applying force.
4. Screw the two 3/8” union nuts on the appliance’s water connection pipes, each fitted with a 3/8” seal, onto the fittings.
5. Screw the plastic knurled retaining nut onto the threaded stud of the wall bracket.
6. Open the water supply to the appliance and slowly open the shut-off valve (see Fig 5) in the cold water connection piece to position 1. Check all connections for leaks.
7. Ensure that all air is eliminated from the water heater by opening and closing the hot water tap until no more air emerges.

Fig 3

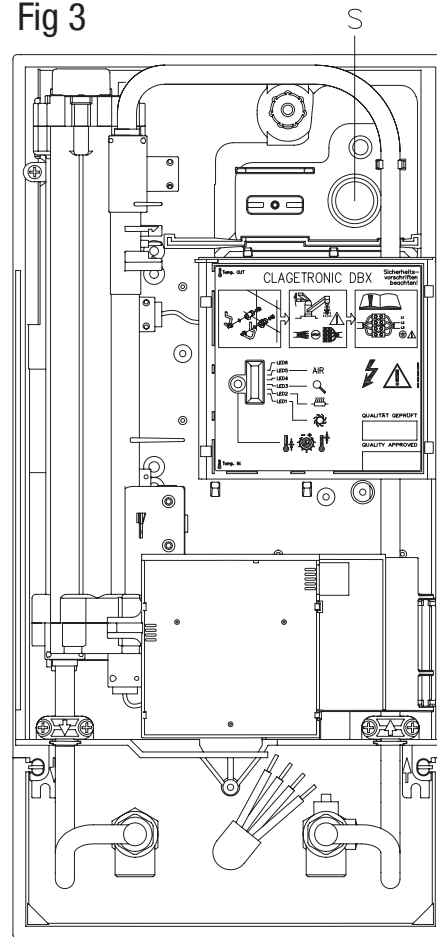

(3-phase model shown)

Fig 4

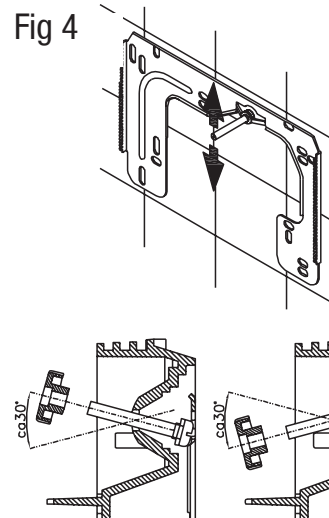
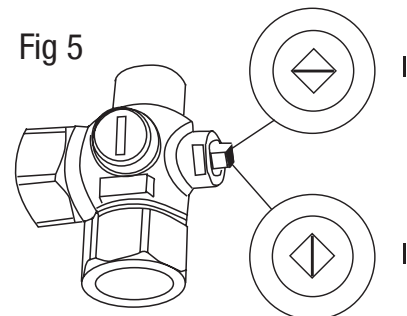

Fig 5



## Surface mounted installation

1. For surface mounting, the two ½" screw-in nipples and the ½" seals must be screwed into the ½" union nuts of the hot water and cold water connectors. The two ½" caps of the side outlets of the hot water and cold water connectors must be removed and screwed into the open end of the screw-in nipples. The hot water and cold water connectors must then be screwed into the ¾" union nut of the appliance and delivery pipe, together with the ¾" seals.
2. When surface mounting, it is advisable to install the appliance at a distance from the wall as illustrated in Fig 6 using the spacer sleeves supplied. In this case the two fixing holes near the lower pipe connections should also be used.
3. The flared end of the pipes must be screwed into the ½" side outlets of the hot water and cold water connectors with ½" union nuts and ½" seals. The holes required for the pipes must then be broken out of the housing using a blunt implement.
4. Ensure the line strainer is inserted into the cold water connection.

## Electrical connection

Prior to commencing electrical connection take time to re-read the 'Installation Requirements' listed on page 6 and ensure that all requirements pertaining to electrical installation are observed.

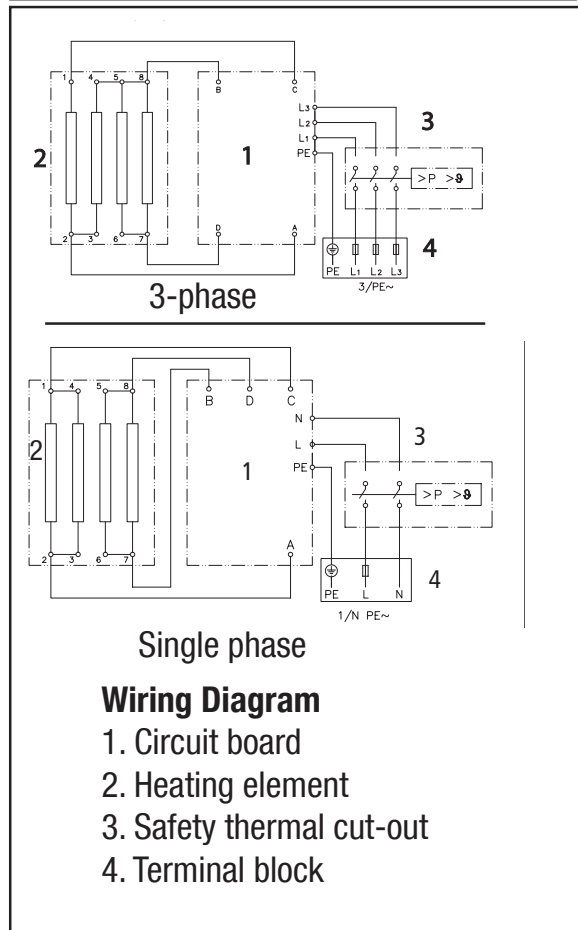
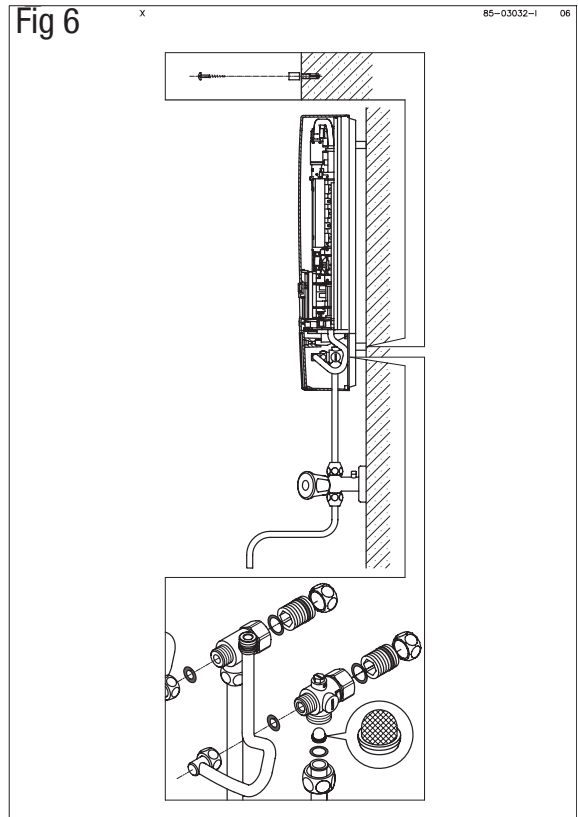

### Load shedding relay (Model DEX only)

If further 3-phase appliances are connected, a load shedding relay (IN82250) can be connected to phase conductor L2. (3-phase models only).

A special operating mode must be selected on the appliance by pressing the four function keys simultaneously until the required mode (0, 1 or 2) is shown on the display then releasing the keys.

First select mode 1 to check correct operation of the load shedding relay at low appliance output (35° set point and low water flow rate). Select mode 2 if the load shedding relay flickers.

### Electrical connection from below

**WARNING** 

**Check that the power supply is switched off prior to electrical connection!**

1. Remove inner and outer insulation from the connecting cable to the lengths shown in Fig 7.
2. With the smaller opening foremost, slide the water splash protection sleeve over the connecting cable until the sleeve is flush with the wall. This prevents any water leaks from coming into contact with the electrical leads. The protection sleeve must be used and free from damage.
3. Open the control panel to the right.
4. Fit the connecting cables into the terminal block according to the wiring diagrams on page 9. Ensure all connections are fully tightened and secure.
5. The appliance must be earthed.
6. Pull the protection sleeve over the connecting cables until it fits in the recess of the intermediate panel.
7. Close the control panel.
8. Re-fit the appliance cover and secure with the fixing screw before re-fitting the fascia panel.

Note: If required, the terminal block can be re-positioned in the upper part of the appliance. In this case the instructions in the following section should be followed.

Mode	Description
0	Normal operation, manufacturer's setting.
1	Operation with normal load shedding relay.
2	Operation with sensitive load shedding relay.

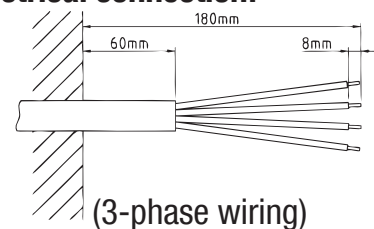

Fig 7

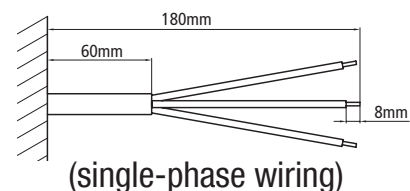
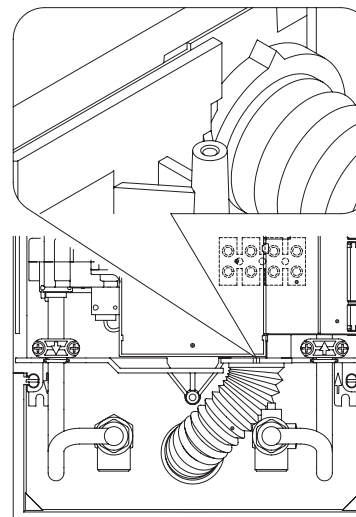

Fig 8 (3-phase model shown)



**Electrical connection from above** (not applicable to model DEX12)

Fig 9  
(3-phase model shown)

**Check the power supply is switched off prior to electrical connection!**

1. Open the prepared breaking point (S) in the upper part of the appliance by pressing with a blunt instrument (e.g. Screwdriver)
2. Open the cable grommet to slightly smaller than the cable size to ensure optimum protection against water ingress. Fit the grommet into the cable opening. N.B. The cable grommet must be used.
3. Strip the cable 6cm above the point where it emerges from the wall. Support the appliance while the cable is routed through the grommet.
4. Unscrew the terminal block fixing screw. Reposition the terminal block on the upper mounting and secure with the fixing screw.
5. Fit the connecting cables into the terminal block according to the wiring diagram on page 9. Ensure all connections are fully tightened and secure.
6. The appliance must be earthed.
7. Re-fit the appliance cover and secure with the fixing screw before re-fitting the fascia panel.

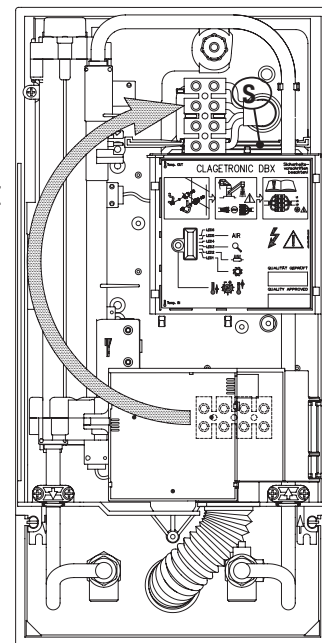

## Commissioning

**CAUTION** ⚠

**To prevent damage to the appliance, the instantaneous water heater must be purged of air before using it for the first time.**

## PURGING

Before connecting the electrical supply, open and close the hot water tap until the water runs smoothly and no more air emerges.

**NOTE! Every time the appliance is drained (e.g. after work on the plumbing system, if there is a risk of frost or following repair work), the heater must be purged in this way before reconnecting the power supply.**

**WARNING!** ⚠ **This appliance must be earthed.**

## Model DEX only

- The maximum power rating of the appliance can be selected from 18, 21, 24 or 27kW (8.8 or 11.0kW for DEX12) at the time of installation. The maximum power rating should only be selected with reference to the technical data on page 4, after ensuring that correct cable sizing and fuse protection is in place and with regard to local site conditions and electrical regulations.
  - This should only be carried out by a competent person familiar with instantaneous water heaters.
1. Switch on the power supply to the appliance. The digital display will light up.

2. When switching on power for the first time “21” (“12” for DEX12) will flash on the display. If not, please refer to the section below “Reinstallation”.
3. Use the arrow up and down function keys to select the required maximum power rating. N.B. DEX at 27kW for connection only to 3/PE **400V** AC supply.
4. Press function key 1 to confirm the selection after which the appliance will start to operate.
5. Mark the set power rating on the product rating plate.
6. After selecting the maximum power rating, the heating element will activate after approximately 30 seconds of water flow.
7. Open the hot water tap and check the appliance is functioning correctly.
8. Explain operation of the appliance to the end user and leave the operating instructions for their reference.
9. Complete the product registration card and return it to Zip Heaters or register the product on line at [www.zipheaters.co.uk](http://www.zipheaters.co.uk)

### DEX Reinstallation

If the appliance is to be re-commissioned under different installation conditions it may be necessary to alter the maximum power rating.

To re-set the maximum power rating use a BS EN 60900 rated screwdriver to short circuit the two pins as shown in Fig 10. Value ‘21’ (“12” for DEX12) will flash in the display panel until the maximum power rating has been selected.

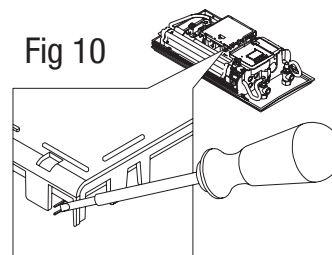

### Model DBX only

N.B. DBX27 for connection only to 3/PE **400V** AC supply.

1. Switch on the power supply to the appliance.
2. Open the hot water tap and check the appliance is functioning correctly.
3. Explain operation of the appliance to the end user and leave the operating instructions for their reference.
4. Complete the product registration card and return it to Zip Heaters or register the product on line at: [www.zipheaters.co.uk](http://www.zipheaters.co.uk)

### DBX Temperature Adjustment

The appliance is factory set to deliver hot water at 50°C.

The hot water temperature can be adjusted between 30°C and 60°C by turning the potentiometer with a 2mm blade screwdriver as shown in Fig 11.

Turning clockwise increases temperature and turning anti-clockwise decreases temperature.

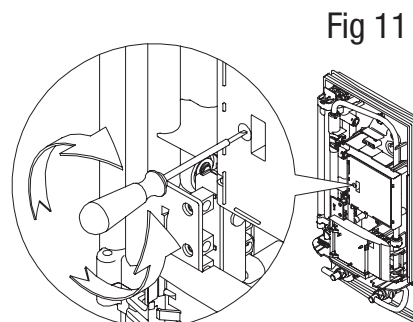



## Maintenance and cleaning.

N.B. Maintenance work must only be carried out by a competent person familiar with instantaneous water heaters.

### General cleaning

Do not use strong, corrosive spray or abrasive cleaners / chemicals.

Clean the casing, tap ware, external filter, piping and all other fittings with a soft cloth and mild soap and water.

Do not spray water over the tap as it may damage the low-voltage electronics.

Caution: Should any of the plastic fittings accidentally come into contact with cleaners with a PH level less than 4, hypochlorite, hydrogen peroxide or any other aggressive chemical the affected component must be replaced immediately.

Undersink units must never be located near, or cleaned with water jets. Avoid using airborne pesticides near the undersink unit.

The electrical and plumbing components should be inspected regularly by a competent person to ensure proper functioning and operational safety. Water quality should be considered when determining the frequency of inspection.

### Cleaning and replacing the filter strainer

The cold water connection of the appliance is fitted with an integral shut-off valve and filter strainer. Soiling of the strainer may reduce hot water output from the unit.

The strainer should be cleaned or replaced as follows:

1. Isolate the electrical supply to the unit.
2. Remove the appliance cover and close the shut-off valve (see Fig 12) in the cold water connection piece to position II.
3. Unscrew the plug (A) from the cold water connection piece and take out the strainer (B) (see Fig 13).
4. The strainer can now be cleaned or replaced.
5. After re-fitting the strainer re-tighten the plug.
6. Slowly open the shut-off valve in the cold water connection piece to position I.
7. Vent the unit by opening and closing the hot water tap several times until all air has been eliminated from the water heater and no more air emerges.
8. Re-fit the appliance cover and restore power to the unit.

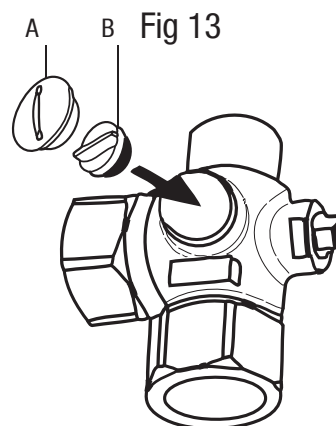
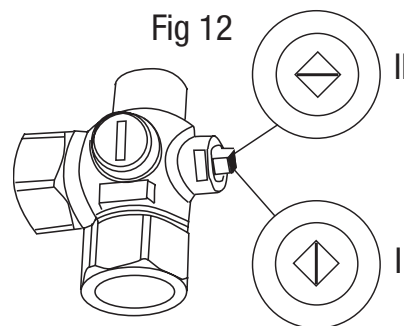

## Operation (Model DEX only)

### Temperature setting

The required hot water temperature can be increased or decreased in increments of 1°C by briefly pressing the up arrow and down arrow function keys.

Depressing the function key for a longer time changes the temperature continuously.

The temperature can be adjusted between 20°C and 60°C. (DEX12 20°C and 55°C)

Note. Reducing the temperature below 20°C displays '- -' and the heating function will not operate.

### Program buttons

The two program keys allow a preset temperature to be selected quickly.

The factory setting is 35°C for program 1 and 48°C for program 2.

The preset temperature can be changed to the current temperature setting by prolonged pressing of the program key.

The display changes from 'P1' or 'P2' to the new temperature value which becomes available each time the corresponding program key is pressed.

### Temperature limitation

Units are supplied with the temperature limitation function deactivated.

To activate, select the limit temperature then press the program 1 and up arrow function keys simultaneously for at least 3 seconds.

'HI' is displayed briefly to confirm activation.

To deactivate, press the program 1 and down arrow function keys simultaneously for at least 3 seconds.

'- -' is displayed briefly to confirm deactivation.

Note. Programmed temperature settings will need to be reset after deactivating temperature limitation.

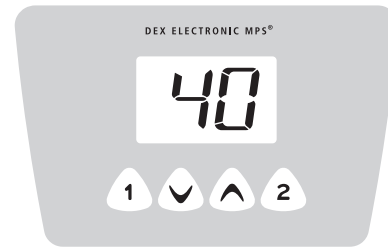

#### Set temperature



#### Select preset temperature

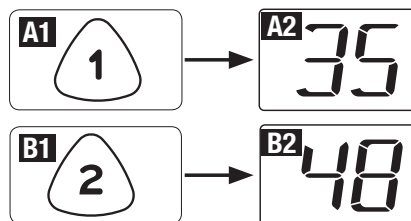

#### Store temperature

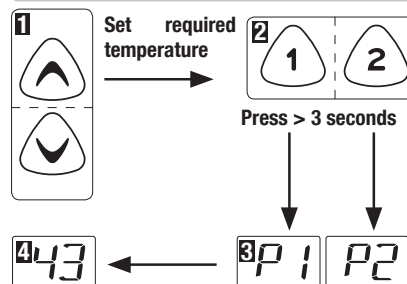

#### Temperature limitation on

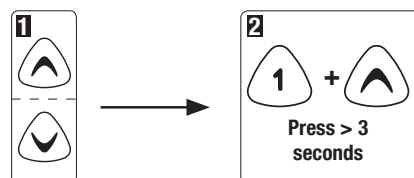

#### Temperature limitation off

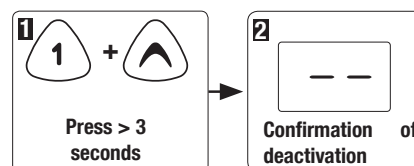



## Reset to factory setting

To reset to factory settings press the up arrow and down arrow function keys simultaneously.

The display will count backwards from '10' to '00' in one second intervals.

The appliance is reset when the counter reaches '00'.

Releasing the function keys earlier will cancel the process.

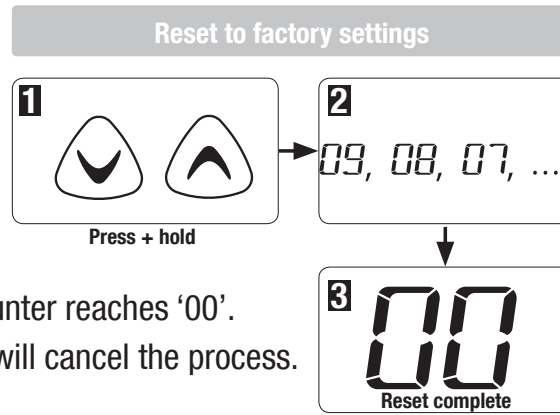

## Energy saving

Set the required hot water temperature on the appliance.

If the water is too hot reduce the temperature on the appliance instead of mixing with cold water.

### **Note! Adding cold water wastes the energy used to heat it up.**

Also, any cold water added is not controlled by the electronic circuitry meaning that precise temperature control can no longer be guaranteed when supplying more than one outlet.

## Power limit

If the maximum power available from the DEX heater is insufficient to heat the volume of hot water being drawn off to the required temperature, this will be indicated by the LCD decimal point on the display.

Reducing the flow rate will enable the required temperature to be delivered indicated by the decimal point remaining solid.

## Operation with solar systems

Type DEX (excluding DEX12\*) are suitable for use with solar heating systems providing appropriate controls are in place to ensure that the temperature of the water entering the unit does not exceed 70°C.

If the inlet temperature exceeds the set point, the flashing decimal point on the display indicates that the heating power is switched off.



**\*Note! DEX12 has a maximum inlet temperature of 25°C.**

## Fault finding

Repairs should only be carried out by competent persons familiar with electric instantaneous water heaters.

All service work should be performed by an authorized Zip service engineer – for details of the full range of services available call Zip Service on 0845 6 005 005 or 0345 6 005 005.

When calling for service, please always specify the appliance model and serial number.

The following table will be helpful in determining the causes of some common problems and their solutions.

Problem	Cause	Solution
Water stays cold (DEX / DBX) Digital display does not light up (DEX)	Circuit breaker tripped	Reset circuit breaker
	STDB tripped (DEX)	Contact Zip Service to reset STDB (DEX)
Display flashes error message 'Er' (DEX)	Control system has switched off	Switch power supply off and on. If 'Er' still flashes contact Zip Service
Poor hot water flow rate (DEX / DBX)	Outlet fitting dirty or calcified	Clean shower head or tap nozzle
	Line strainer dirty or calcified	Contact Zip Service to clean line filter
Selected temperature not achieved (DEX / DBX) Decimal point flashes (DEX)	Excessive water flow rate	Reduce water flow rate at the outlet
Selected temperature not achieved and decimal point does not flash (DEX)	Cold water has been added at the outlet	Set for required temperature and tap hot water only
Decimal point flashes (DEX)	Inlet temperature exceeding set point	Reduce inlet temperature
Delivered temperature perceived to be too cold (DBX)	Set temperature too low	Contact Zip Service to increase set temperature
Delivered temperature perceived to be too hot (DBX)	Set temperature too high	Contact Zip Service to reduce set temperature
No response to keypress (DEX)	Appliance cover not fitted correctly	Refit appliance cover correctly

## Warranty

The Zip appliance you have chosen is precision-built from the finest materials available and should give many years of trouble free service.

Certain warranties may be implied by law into your contract with Zip.

The warranty provided below is additional to these implied warranties and nothing set out below shall limit your statutory rights or rights at law.

Zip Heaters (UK) Ltd warrants that, should any part fail within 12 calendar months of installation, that part will be repaired or replaced free of charge by Zip or its Distributor or Service Provider, except as set out below, provided the appliance is installed and used strictly in accordance with the instructions supplied, and that failure is not due to accident, misuse, abuse, unsuitable water conditions, or to any alteration, modification or repair by any party not expressly nominated by Zip.

No costs are payable by the customer other than any mileage or travelling-time charges incurred by a Zip Service Provider or the cost of removal, cartage and re-installation of any component of the appliance if it needs to be returned for repair to Zip or its Distributor.

This warranty does not cover damage resulting from non-operation of the appliance or consequential damage to any other goods, furnishings or property. Zip does not exclude, restrict or modify any liability that cannot be excluded, restricted or modified or which cannot, except to a limited extent, be excluded, restricted or modified as between the owner or user and Zip under the laws applicable.

Furthermore, this warranty does not displace any statutory warranty, but, to the extent to which Zip is entitled to do so, the liability of Zip under any statutory warranty will be limited at Zip's option to the replacement of the appliance or supply of equivalent appliance, the payment of the cost of replacing the appliance or acquiring an equivalent appliance, or the payment of the cost of replacing the appliance or acquiring an equivalent appliance, or the payment of the cost of having the appliance repaired or the repair of the appliance.



The use of this crossed out wheeled bin logo indicates that this product needs to be disposed of separately to any other household waste.

Within each of the European Union member countries, provisions have been made for the collection and recycling of unwanted electrical and electronic equipment.

In order to preserve our environment we ask that you dispose of this product correctly. Please contact Zip Customer Service for advice on 0845 6 005 005 or 0345 6 005 005